

RC2951

Adjustable Micropower Voltage Regulator

Features

- High accuracy output voltage
- Guaranteed 100 mA output current
- Extremely low quiescent current
- Extremely tight load and line regulation
- Requires only a 1.0 μ F output capacitor for stability
- Internal Current and Thermal Limiting
- Error flag warns of output dropout
- Logic-controlled electronic shutdown
- Output programmable from 1.24 to 29V
- Fixed 3.3V version available
- 8 lead SOIC package

Description

The RC2951 is a voltage regulator specifically designed to maintain proper regulation with a very low dropout voltage (Typ. 40mV at light loads and 380 mV at 100mA). It has a low quiescent bias current of 75 μ A and is capable of supplying output currents in excess of 100mA. It has internal current and thermal limiting protection. The output can be programmed from 1.24V to 29V with two external resistors. A fixed output voltage (3.3V) is also available.

The error flag output can be used as power-on reset for warning of a low output voltage. The Shutdown input feature allows a logic level signal to turn on and off the regulator output. The RC2951 is ideally suited for battery powered computer, consumer, and industrial equipment where an extension of useful battery life is desirable. The RC2951 is available in an 8-pin SOIC package.

Block Diagram

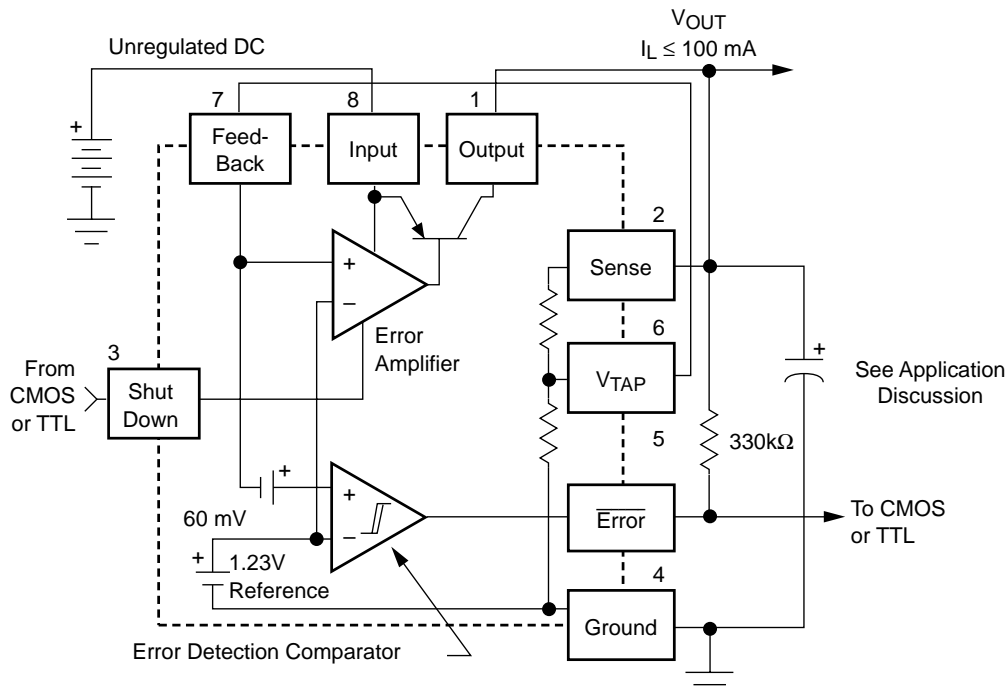

Rev. 0.9.3

Pin Assignments

8 Lead SOIC Package

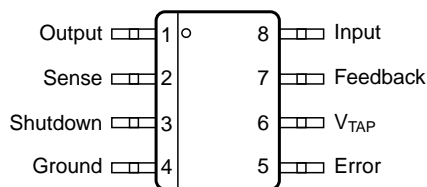

Top View

Absolute Maximum Ratings

Power Dissipation	Internally Limited
Lead Temp. (Soldering, 5 seconds)	260°C
Storage Temperature Range	-65° to +150°C
Operating Junction Temperature Range ¹	-55° to +150°C
Input Supply/Voltage	-0.3 to +30V
Feedback Input Voltage ^{2,3}	-1.5 to +30V
Shutdown Input Voltage ²	-0.3 to +30V
Error Comparator Output Voltage ²	-0.3 to +30V

Notes:

1. Junction to ambient thermal resistance for the S.O. (M) package is 160°C/W.
2. May exceed input supply voltage.
3. When used in dual-supply systems where the output terminal sees loads returned to a negative supply, the output voltage should be diode-clamped to ground.

Electrical Characteristics

The • denotes that the limits apply at temperature extremes.

Parameter	Conditions ¹	Typ.	Tested Limit ²	Units	
Output Voltage (RC2951M)	$T_J = 25^\circ\text{C}$	5.0	5.025 4.975	V max V min	
	$-25^\circ\text{C} \leq T_J \leq 85^\circ\text{C}$	5.0		V max V min	
	Full Operating Temperature Range	• •	5.0	5.06 4.94	V max V min
Output Voltage (RC2951M)	$100\mu\text{A} \leq I_L \leq 100\text{mA}$ $T_J \leq T_{JMAX}$	• •	5.075 4.925	V max V min	
	$T_J = 25^\circ\text{C}$		3.3	3.317 3.284	V max V min
Output Voltage (RC2951M-3.3)	$-25^\circ\text{C} \leq T_J \leq 85^\circ\text{C}$		3.3	V max V min	
	Full Operating Temperature Range	• •	3.3	3.340 3.260	V max V min
	$100\mu\text{A} \leq I_L \leq 100\text{mA}$ $T_J \leq T_{JMAX}$	• •	3.3	3.346 3.254	V max V min
Output Voltage Temperature Coefficient ⁷		•	20	120 ppm/°C	

Electrical Characteristics (continued)

The • denotes that the limits apply at temperature extremes.

Parameter	Conditions ¹		Typ.	Tested Limit ²	Units
Line Regulation ^{9, 10}	$(V_{ONOM} + 1)V \leq V_{in} \leq 20V$	•	0.03	0.1 0.5	% max % max
Load Regulation ⁹	$100 \mu A \leq I_L \leq 100 mA$	•	0.08	0.2 0.4	% max % max
Dropout Voltage ³	$I_L = 100 \mu A$	•	50	80 150	mV max mV max
	$I_L = 100 mA$	•	380	500 700	mV max mV max
Ground Current	$I_L = 100 \mu A$	•	75	120 140	μA max μA max
	$I_L = 100 mA$	•	8	14 15	mA max mA max
Dropout Ground Current	$V_{in} = (V_{ONOM} - 0.5)V$ $I_L = 100 \mu A$	•	110	250 300	μA max μA max
Current Limit	$V_{out} = 0$	•	160	200 220	mA max mA max
Thermal Regulation ⁸			0.05	0.2	%/W max
Output Noise, 10 Hz to 100 KHz	$C_L = 1 \mu F$ (5V Only)		430		μV rms
	$C_L = 200 \mu F$		160		μV rms
	$C_L = 3.3 \mu F$ (Bypass = 0.01 μF Pins 7 to 1 (RC2951))		100		μV rms
Reference Voltage		• •	1.235	1.25 1.26 1.22 1.2	V max V max V min V min
Reference Voltage ⁵		• •		1.27 1.19	V max V min
Feedback Pin Bias Current		•	20	40 60	nA max nA max
Reference Voltage Temperature Coefficient ⁷			20		ppm/°C
Feedback Pin Bias Current Temperature Coefficient			0.1		nA/°C
Error Comparator					
Output Leakage Current	$V_{OH} = 30V$	•	0.01	1 2	μA max μA max
Output Low Voltage	$V_{in} = (V_{ONOM} - 0.5)V$ $I_{OL} = 400 \mu A$	•	150	250 400	mV max mV max
Upper Threshold Voltage ⁴		•	60	40 25	mV min mV min
Lower Threshold Voltage ⁴		•	75	95 140	mV max mV max
Hysteresis ⁴			15		mV

Preliminary Information

Electrical Characteristics (continued)

The • denotes that the limits apply at temperature extremes.

Parameter	Conditions ¹	Typ.	Tested Limit ²	Units
Shutdown Input				
Input Logic Voltage	Low (Regulator ON)	•	1.3	V
	High (Regulator OFF)	•		
Shutdown Pin Input Current	$V_{\text{shutdown}} = 2.4\text{V}$	•	30	50 100
	$V_{\text{shutdown}} = 30\text{V}$	•	450	600 750
Regulator Output Current in Shutdown ⁶		•	3	10 20

Notes:

- Unless otherwise specified all limits guaranteed for $T_J - 25^\circ\text{C}$, $V_{\text{in}} = (V_{\text{ONOM}} + 1)\text{V}$, $I_L = 100\mu\text{A}$ and $C_L = 1\mu\text{F}$ for 5V versions, and 2.2 μF for 3V and 3.3V versions. Additional conditions for the 8-pin versions are Feedback tied to V_{TAP} , Output tied to Output Sense and $V_{\text{shutdown}} < 0.8\text{V}$.
- Guaranteed and 100% production tested.
- Dropout Voltage is defined as the input to output differential at which the output voltage drops 100 mV below its nominal value measured at 1V differential. At very low values of programmed output voltage, the minimum input supply voltage of 2V (2.3V over temperature) must be taken into account.
- Comparator thresholds are expressed in terms of a voltage differential at the Feedback terminal below the nominal reference voltage measured at $V_{\text{in}} = (V_{\text{ONOM}} + 1)\text{V}$. To express these thresholds in terms of output voltage change, multiply by the error amplifier gain = $V_{\text{out}}/V_{\text{ref}} = (R1 + R2)/R2$. For example, at a programmed output voltage of 5V, the Error output is guaranteed to go low when the output drops by $95\text{ mV} \times 5\text{V}/1.235\text{V} = 384\text{ mV}$. Thresholds remain constant as a percent of V_{out} as V_{out} is varied, with the dropout warning occurring at typically 5% below nominal, 7.5% guaranteed.
- $V_{\text{ref}} < V_{\text{out}} \leq (V_{\text{in}} - 1\text{V})$, $2.3\text{V} \leq V_{\text{in}} \leq 30\text{V}$, $100\mu\text{A} \leq I_L \leq 100\text{ mA}$, $T_J \leq T_{\text{JMAX}}$.
- $V_{\text{shutdown}} \geq 2\text{V}$, $V_{\text{in}} \leq 30\text{V}$, $V_{\text{out}} = 0$, Feedback pin tied to V_{TAP} .
- Output or reference voltage temperature coefficient is defined as the worst case voltage change divided by the total temperature range.
- Thermal regulation is defined as the change in output voltage at a time T after a change in power dissipation is applied, excluding load or line regulation effects. Specifications are for a 50 mA load pulse at $V_{\text{IN}} = 30\text{V}$ (1.25W pulse) for $T = 10\text{ ms}$.
- Regulation is measured at constant junction temperature, using pulse testing with a low duty cycle. Changes in output voltage due to heating effects are covered under the specification for thermal regulation.
- Line regulation for the RC2951 is tested at 150°C for $I_L = 1\text{ mA}$. For $I_L = 100\mu\text{A}$ and $T_J = 125^\circ\text{C}$, line regulation is guaranteed by design to 0.2%. See Typical Performance Characteristics for line regulation versus temperature and load current.

Applications Discussion

The RC2951 regulator is designed with internal current limiting and thermal shutdown. It is not internally compensated and requires a 1.0 μ F (or greater) capacitor between the output terminal and ground for stability. At lower output voltages, more capacitance is required (2.2 μ F or more is recommended for 3V and 3.3V versions) for stability. Most types of aluminum, tantalum or multilayer ceramic capacitors will perform adequately. Solid tantalums or appropriate multilayer ceramic capacitors are suggested for operation below 25°C. At lower values of output current, less capacitance is needed to maintain stability at output. The capacitor at the output can be reduced to 0.33 μ F for currents less than 10mA, or 0.1 μ F for currents below 1.0mA.

Using the adjustable versions at voltages below 5V runs the error amplifier at lower gains so that more output capacitance is needed. For the worst-case situation of a 100 mA load at 1.23V output (Output shorted to Feedback) a 3.3 μ F (or greater) capacitor should be used.

When setting the output voltage of the RC2951 versions with external resistors, a minimum load of 1 μ A is recommended. A 1 μ F tantalum or aluminum electrolytic capacitor should be placed from the RC2951 input to ground if there is more than 10 inches of wire between the input and the AC filter capacitor or if a battery is used as the input.

Stray capacitance to the RC2951 Feedback terminal can cause instability. This may especially be a problem when using high value external resistors to set the output voltage. Adding a 100 pF capacitor between Output and Feedback and increasing the output capacitor to at least 3.3 μ F will fix this problem.

Error Detection Comparator Output

The comparator switches to a logic low whenever the RC2951 output falls out of regulation by more than approximately 5%. This value is the comparator's built-in offset of about 60 mV divided by the 1.235 internal reference voltage. This trip level remains "5% below normal" regardless of the value of the output voltage. For example, the error flag trip level is typically 4.75V for a 5V output or 11.4V for a 12V output. The out of regulation condition may be due either to low input voltage, current limiting, or thermal limiting.

Figure 1 is a timing diagram showing the $\overline{\text{ERROR}}$ signal and the regulated output voltage as the RC2951 input is ramped up and down. For 5V versions, the $\overline{\text{ERROR}}$ signal becomes valid (low) at about 1.3V input. It goes high at about 5V input (the input voltage at which $V_{\text{OUT}} = 4.75\text{V}$.) Since the RC2951's dropout voltage is load-dependent (see curve in typical performance characteristics), the input voltage trip point (about 5V) will vary with the load current. The output voltage trip point (approx. 4.75V) does not vary with load.

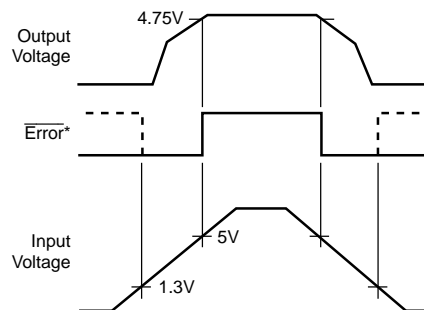
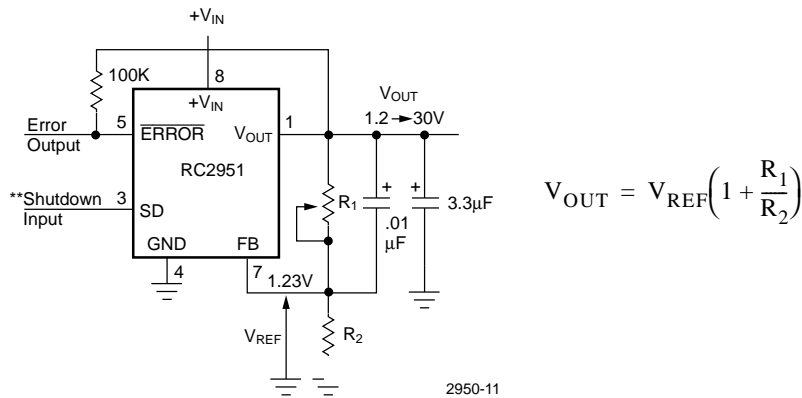

Figure 1. $\overline{\text{ERROR}}$ Output Timing

The error comparator has an open-collector output which requires an external pullup resistor. This resistor may be returned to the output or some other supply voltage depending on system requirements. In determining a value for this resistor, note that while the output is rated to sink 400 μ A, this sink current adds to battery drain in a low battery condition. Suggested values range from 100k to 1M Ω . The resistor is not required if this output is unused.

Programming the Output Voltage (RC2951)

The RC2951 may be pin-strapped for the nominal fixed output voltage using its internal voltage divider by tying the output and sense pins together, and also tying the feedback and V_{TAP} pins together. Alternatively, it may be programmed for any output voltage between its 1.235V reference and its 30V maximum rating. As seen in Figure 2 an external pair of resistors is required.



** Drive with TTL-high to shut down. Ground or leave open if shutdown feature is not to be used.

Figure 2. Adjustable Regulator

The complete equation for the output voltage is

$$V_{OUT} = V_{REF} \cdot \left(1 + \frac{R_1}{R_2}\right) + I_{FB} R_1$$

$$\frac{V_{REF}}{R_2} = \frac{V_{OUT}}{R_1 + R_2}$$

$$V_{OUT} = V_{REF} \left(\frac{R_1 + R_2}{R_2}\right)$$

$$V_{OUT} = V_{REF} \left(1 + \frac{R_1}{R_2}\right)$$

Adding the error term,

$$V_{OUT} = V_{REF} \left(1 + \frac{R_1}{R_2}\right) + I_{FB} R_2$$

where V_{REF} is the nominal 1.235 reference voltage and I_{FB} is the feedback pin bias current, nominally -20 nA. The minimum recommended load current of 1 μ A forces an upper limit of 1.2 M Ω on the value of R_2 , if the regulator must work with no load (a condition often found in CMOS in standby). I_{FB} will produce a 2% typical error in V_{OUT} which may be eliminated at room temperature by trimming R_1 . For better accuracy, choosing $R_2 = 100k$ reduces this error to 0.17% while increasing the resistor program current to 12 μ A. Since the RC2951 typically draws 60 μ A at no load with Pin 2 open-circuited, this is a small price to pay.

Reducing Output Noise

In reference applications it may be advantageous to reduce the AC noise present at the output. One method is to reduce the regulator bandwidth by increasing the size of the output capacitor.

Noise can be reduced fourfold by a bypass capacitor across R_1 , since it reduces the high frequency gain from 4 to unity. Pick

$$C_{BYPASS} \cong \frac{1}{2\pi R_1 \cdot 200\text{Hz}}$$

or about 0.01 μ F. When doing this, the output capacitor must be increased to 3.3 μ F to maintain stability. These changes reduce the output noise from 430 μ V to 100 μ V rms for a 100 kHz bandwidth at 5V output. With the bypass capacitor added, noise no longer scales with output voltage so that improvements are more dramatic at higher output voltages.

Typical Applications

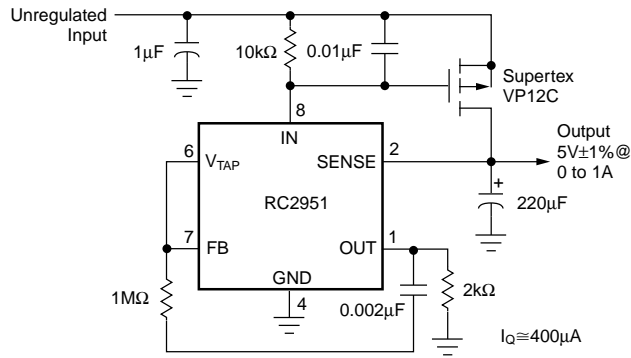

Figure 3. 1A Regulator with 1.2V Dropout

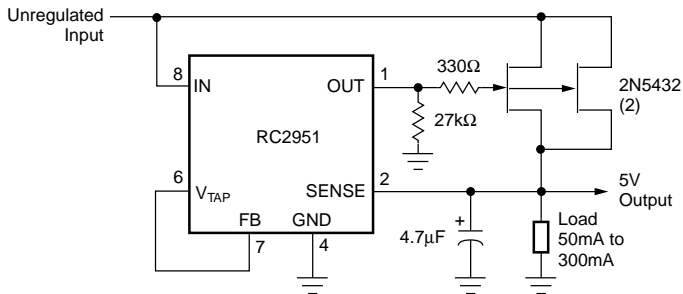

Figure 4. 300 mA Regulator with 0.75V Dropout

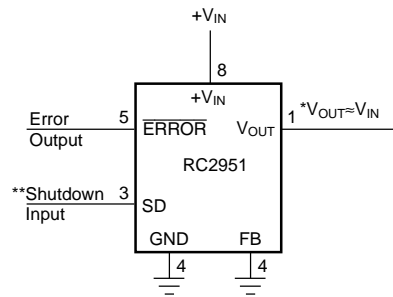

Figure 5. Wide Input Voltage Range Current Limiter

*Minimum input-output voltage ranges from 40 mV to 400 mV, depending on load current. Current limit is typically 160 mA.

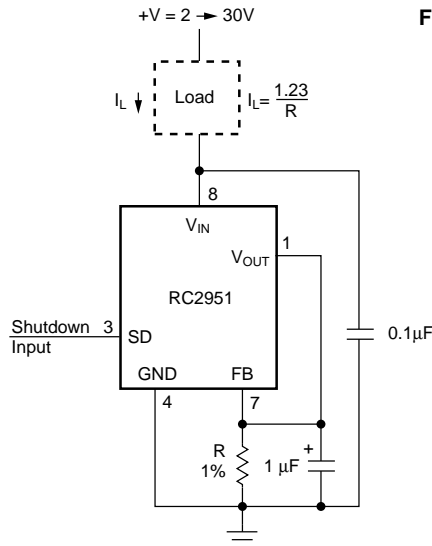
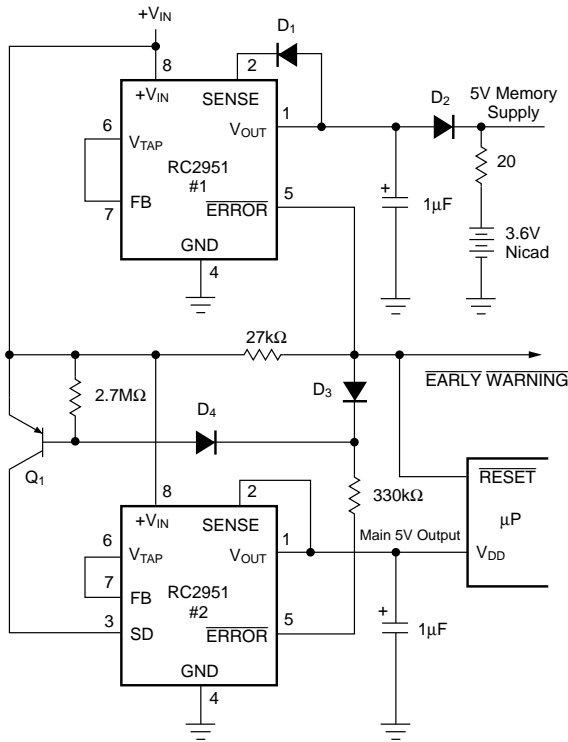

Figure 6. Low Drift Current Source

Preliminary Information

Typical Applications (continued)

Preliminary Information



- Early warning flag on low input voltage
 - Main output latches off at lower input voltages
 - Battery backup on auxiliary output
- Operation Reg. #1's V_{OUT} is programmed one diode drop above 5V. Its error flag becomes active when $V_{IN} \leq 5.7V$. When V_{IN} drops below 5.3V, the error flag of Reg. #2 becomes active and via Q1 latches the main output off. When V_{IN} again exceeds 5.7V Reg. #1 is back in regulation and the early warning signal rises unlatching Reg. #2 via D3.

Figure 7. Regulator with Early Warning and Auxiliary Output

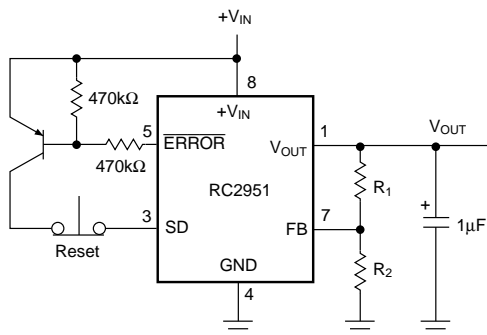
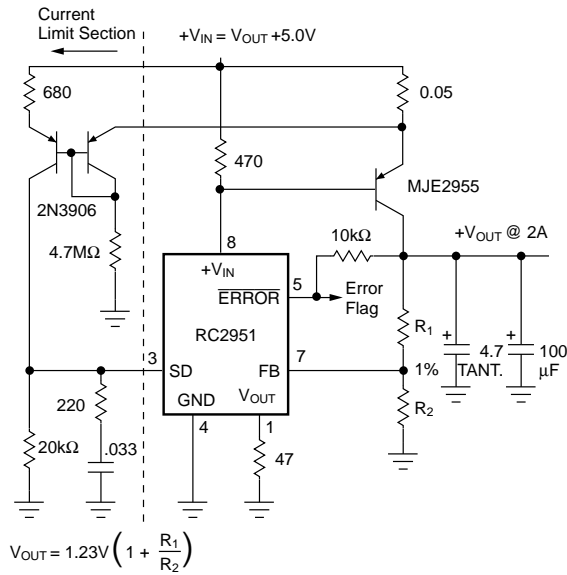

Figure 8. Latch Off When Error Flag Occurs



$$V_{OUT} = 1.23V \left(1 + \frac{R_1}{R_2} \right)$$

For V_{OUT} , use internal resistors. Wire pin 6 to 7, & wire pin 2 to $+V_{OUT}$ Buss.

Figure 9. 2 Ampere Low Dropout Regulator

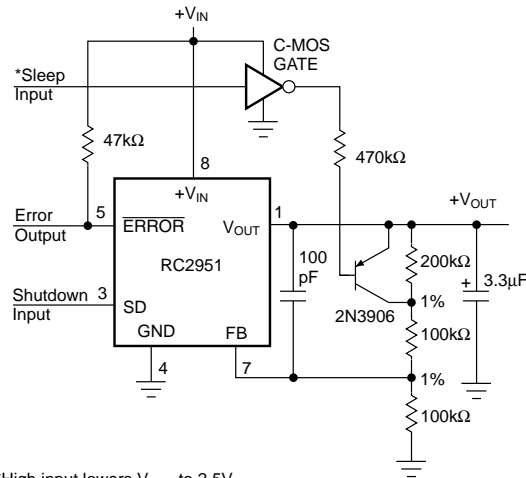

*High input lowers V_{OUT} to 2.5V.

Figure 10. 5V Regulator with 2.5V Sleep Function

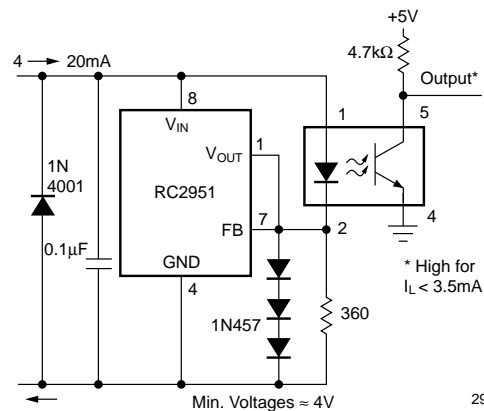
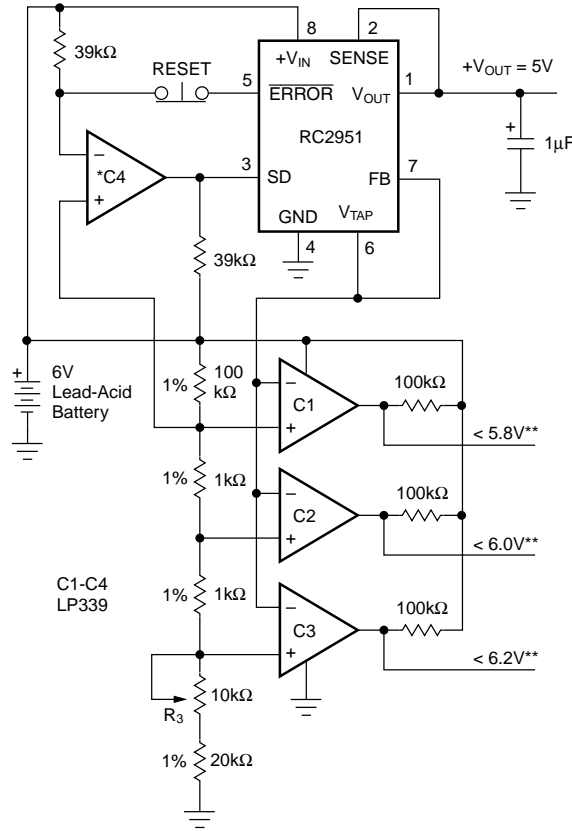

Figure 11. Open Circuit Detector for 4mA to 20mA Current Loop

Typical Applications (continued)



*Optional Latch off when drop out occurs. Adjust R3 for C2 Switching when V_{in} is 6.0V.
 **Outputs go low when V_{in} drops below designated thresholds.

Figure 12. Regulator with State-of-Charge Indicator

For values shown, Regulator shuts down when $V_{in} < 5.5V$ and turns on again at 6.0V. Current drain in disconnected mode is $\approx 150 \mu A$.

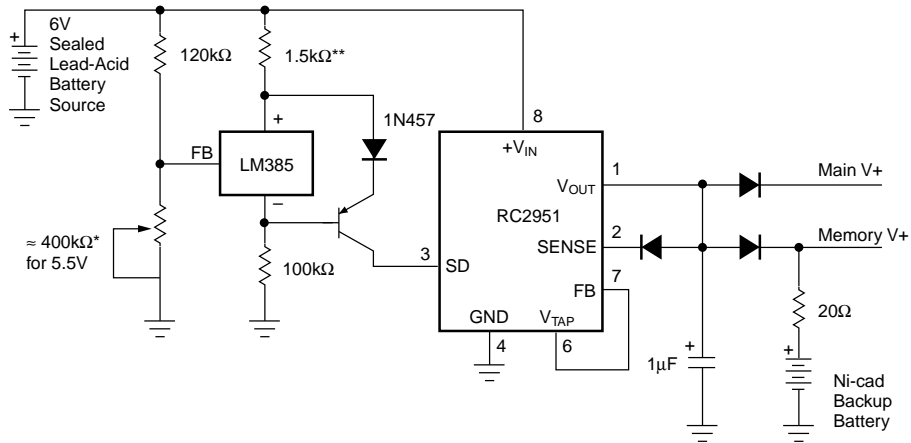

*Sets disconnect Voltage
 **Sets disconnect Hysteresis

Figure 13. Low Battery Disconnect

Notes:

Preliminary Information

Mechanical Dimensions – 8 Lead SOIC

Symbol	Inches		Millimeters		Notes
	Min.	Max.	Min.	Max.	
A	.053	.069	1.35	1.75	
A1	.004	.010	0.10	0.25	
B	.013	.020	0.33	0.51	
C	.008	.010	0.20	0.25	5
D	.189	.197	4.80	5.00	2
E	.150	.158	3.81	4.01	2
e	.050 BSC		1.27 BSC		
H	.228	.244	5.79	6.20	
h	.010	.020	0.25	0.50	
L	.016	.050	0.40	1.27	3
N	8		8		6
α	0°	8°	0°	8°	
ccc	—	.004	—	0.10	

Notes:

1. Dimensioning and tolerancing per ANSI Y14.5M-1982.
2. "D" and "E" do not include mold flash. Mold flash or protrusions shall not exceed .010 inch (0.25mm).
3. "L" is the length of terminal for soldering to a substrate.
4. Terminal numbers are shown for reference only.
5. "C" dimension does not include solder finish thickness.
6. Symbol "N" is the maximum number of terminals.

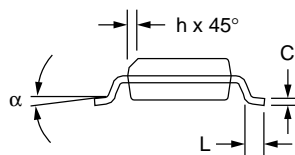
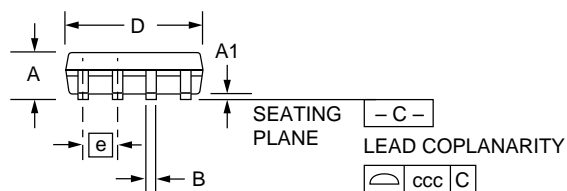
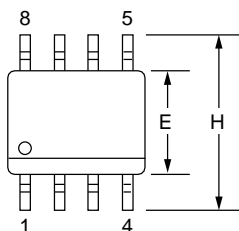

Preliminary Information

Ordering Information

Product Number	Package
RC2951M	8 pin SOIC
RC2951M-3.3	8 pin SOIC

Preliminary Information

The information contained in this data sheet has been carefully compiled; however, it shall not by implication or otherwise become part of the terms and conditions of any subsequent sale. Raytheon's liability shall be determined solely by its standard terms and conditions of sale. No representation as to application or use or that the circuits are either licensed or free from patent infringement is intended or implied. Raytheon reserves the right to change the circuitry and any other data at any time without notice and assumes no liability for errors.

LIFE SUPPORT POLICY:

Raytheon's products are not designed for use in life support applications, wherein a failure or malfunction of the component can reasonably be expected to result in personal injury. The user of Raytheon components in life support applications assumes all risk of such use and indemnifies Raytheon Company against all damages.

Raytheon Electronics
Semiconductor Division
350 Ellis Street
Mountain View, CA 94043
415.968.9211
FAX 415.966.7742